

DesignCon 2003

High-Performance System Design Conference (HP3-5)

“Logic Analyzer Probing Techniques for High-Speed Digital Systems”

Author/Presenter:

Brock LaMeres
Hardware Design Engineer
Logic Analyzer Probing



Agilent Technologies

Objective

- 1) Predict the electrical effect of a Logic Analyzer Probe on the target
- 2) Predict the electrical effect of the target on the Logic Analyzer Probe
- 3) Help in the selection of a Logic Analyzer Probe
- 4) Present specific logic analyzer probing techniques
- 5) Present what is currently available for Logic Analyzer Probing solutions

The Logic Analyzer



- **A logic analyzer is a piece of general purpose, test equipment**
- **It provides debug/validation for digital systems**
- **It is connected to the target system using a probe**



The Probe

- Provides the “electrical” connection from the target to the analyzer
- Provides the “mechanical” connection from the target to the analyzer
- Both are important factors in selecting a probe

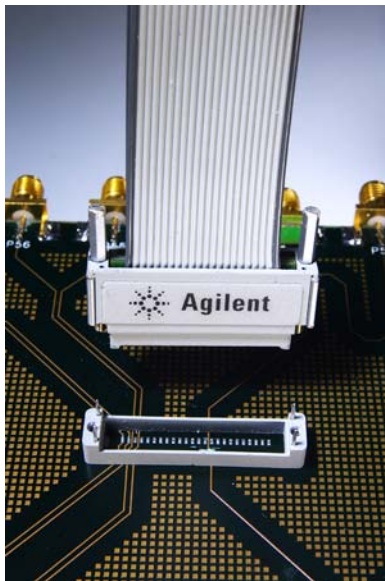

Electrical Considerations of a Probe

- **Electrical Loading on the Target System**
- **Signal Quality at the Tip of the Probe**

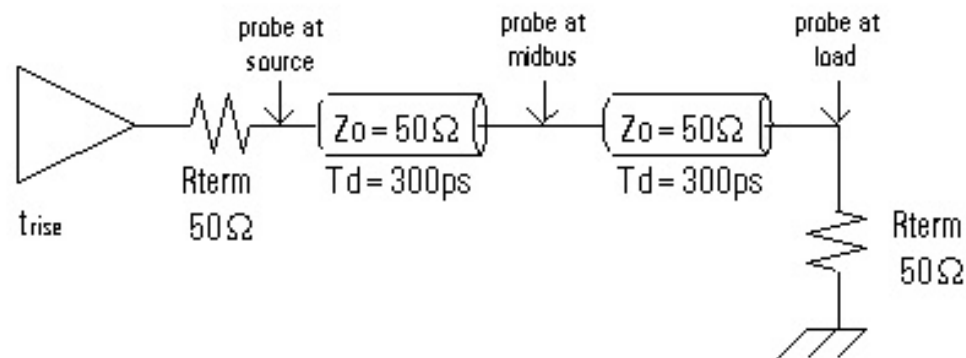

- **The Topology of the Target System Affects Both**
- **The Location of the Probe Affects Both**

How can we Predict the Affect of the Probe?

- **Logic Analyzer Vendors provide electrical specifications about the probes**
 - **Equivalent Load Models (SPICE Decks)**
 - **Equivalent Lumped Capacitance**
 - **Impedance Profiles**
 - **Maximum Data Rates / Minimum Amplitudes**

SPICE Simulation

- **The most accurate method of prediction is to simulate the equivalent load**

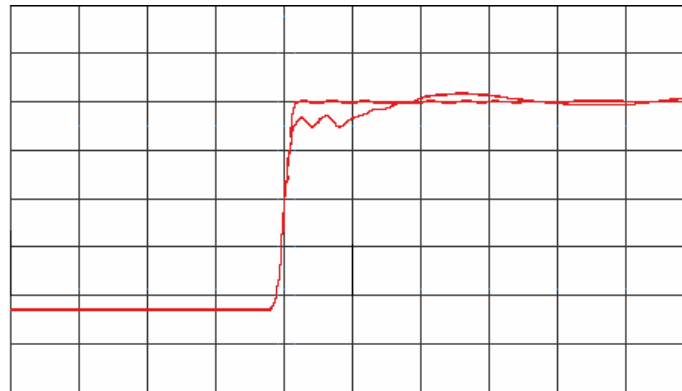

- **Sometimes we want a quicker method to estimate the probe affect**
- **We must understand the response of the probe circuit**

The Simplified Electrical Model of the Probe

- The probe's goal is to have a **HIGH** impedance

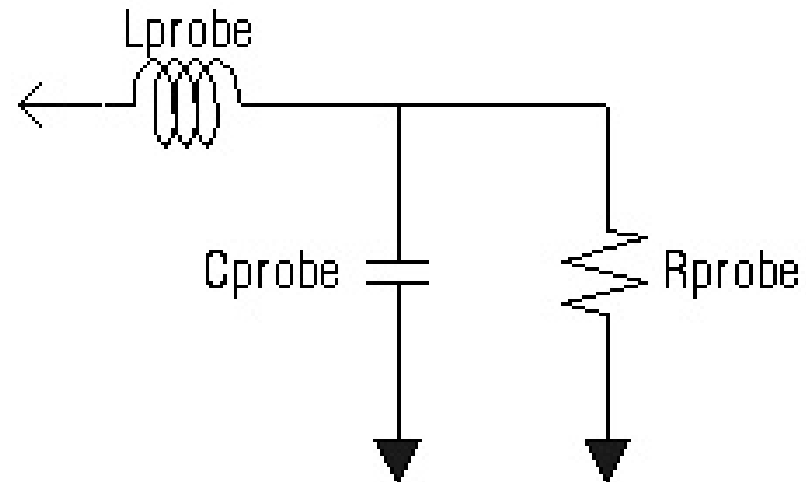

- However, there will always be:
 - series Inductance
 - parallel capacitance
 - parallel resistance

Lumped Capacitance Model

- **If we assume that:
the series inductance is small
and
the parallel resistance is high**

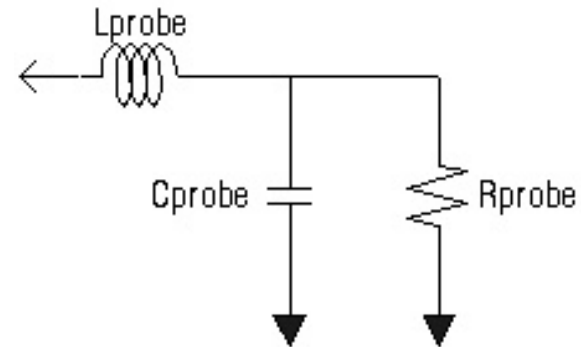

- **The probe can be estimated as a lumped capacitance**
- **This is useful for quick hand calculations**
- **This is NOT as accurate as simulation**

Lumped Capacitance Model (Hand Calculation #1)

System Risetime **without** Probe

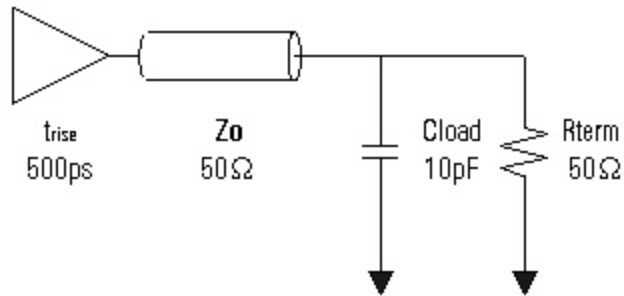

$$\tau_{load} = R \cdot C = (50 // 50) \cdot (10p) = 250ps$$

$$t_{riseload} = 2.2 \cdot \tau_{load} = 550ps$$

$$t_{risetys} = \sqrt{(500ps)^2 + (550ps)^2} = 743ps$$

System Risetime **with** Probe (Cprobe=1.5pF)

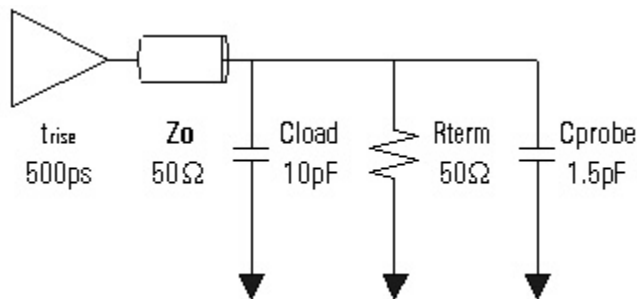

$$\tau_{load} = R \cdot C = (50 // 50) \cdot (11.5p) = 288ps$$

$$t_{riseload} = 2.2 \cdot \tau_{load} = 632ps$$

$$t_{risetys} = \sqrt{(500ps)^2 + (632ps)^2} = 806ps$$

$$\%_{RisetimeRoll-off} = 8.5\%$$

Lumped Capacitance Model (Hand Calculation #2)

System Risetime **with** Probe (Now probed in middle of bus)

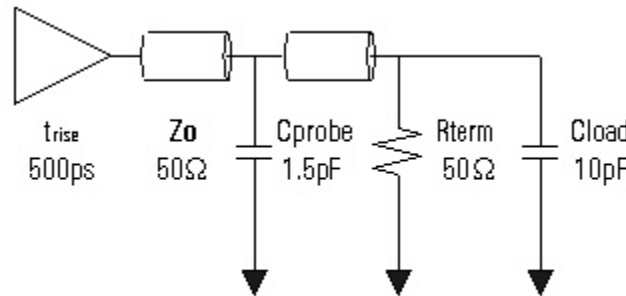

$$t_{riseload} = 550\text{ps}$$

$$\tau_{probe} = R \cdot C = (50 // 50) \cdot (1.5\text{p}) = 38\text{ps}$$

$$t_{riseprobe} = 2.2 \cdot \tau_{probe} = 83\text{ps}$$

$$t_{risetotal} = \sqrt{(500\text{ps})^2 + (550\text{ps})^2 + (83\text{ps})^2} = 748\text{ps}$$

$$\% \text{ RisetimeAdd-off} = 0.7\%$$

-Notice: the location of the probe affects the response of the system

**-This method of prediction is quick and estimates to the 1st order.
Not recommended if margins are tight**

Impedance Profile

-Another method of prediction is to view the probe's impedance profile

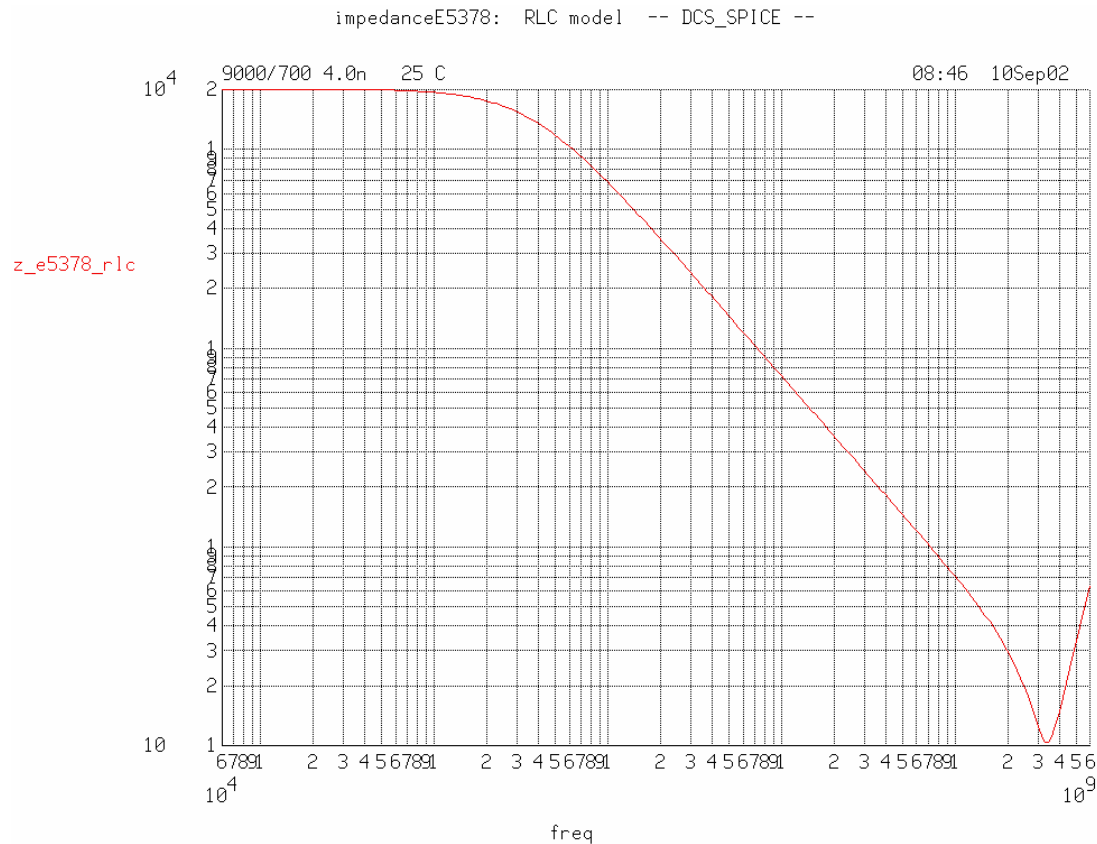

Impedance Profile - Where does it come from?

- A Voltage Network Analyzer is used to measure the load of the probe
- A ~perfect 50Ω system is built and calibrated on the VNA
- The parallel load of the probe is then connected
- The transmitted response is then measured on the VNA (S21)
- An equivalent RLC model is then built to match the VNA response

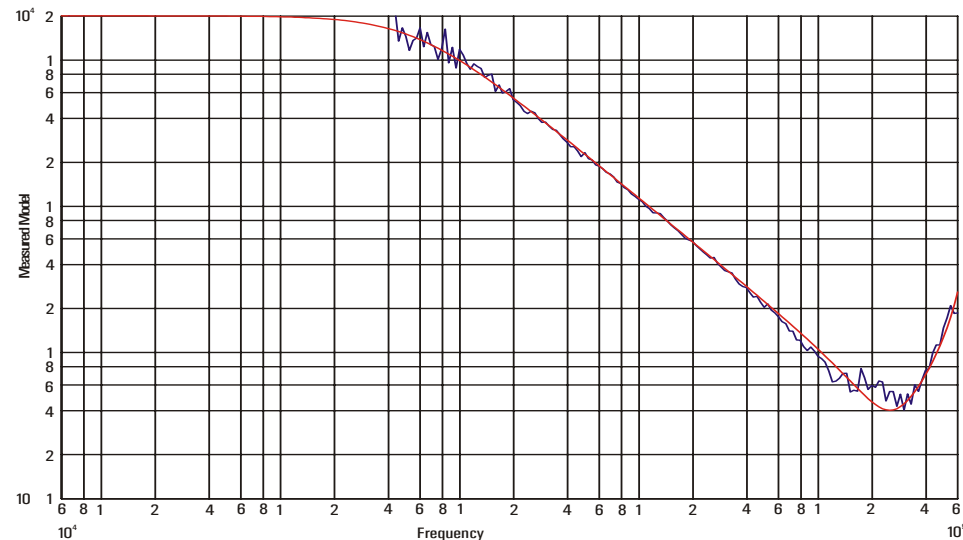

Impedance Profile – What does it mean?

-Notice the RLC nature of the response

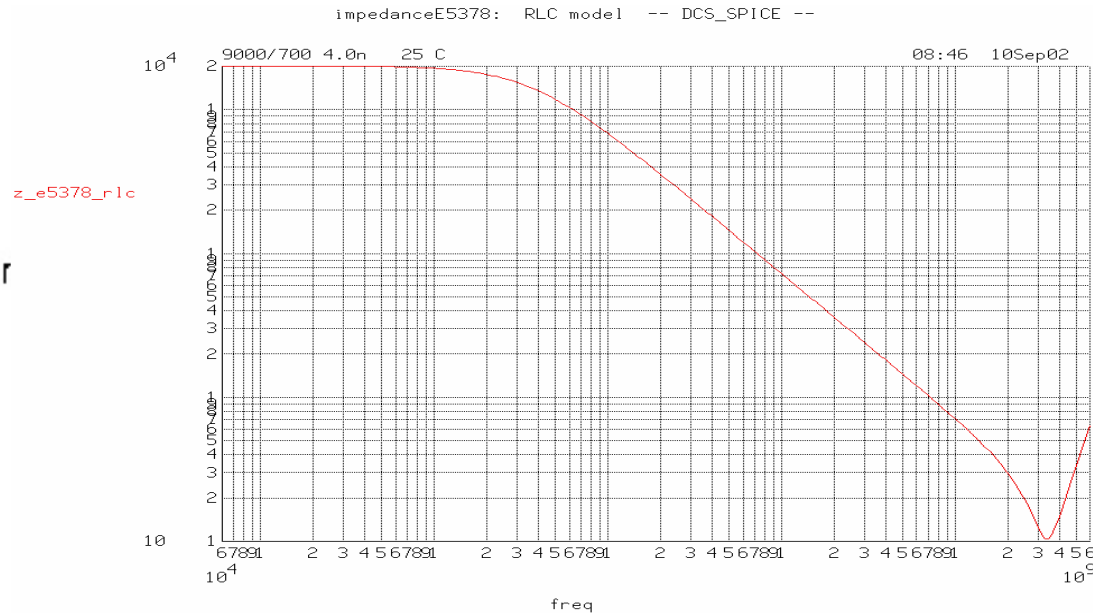
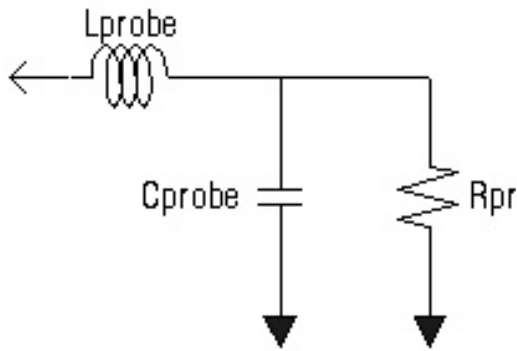

- Notice the resonant frequency
- Notice the frequency at which the impedance becomes:

$228 \Omega's \Rightarrow 228 // 50 = 41 \Omega's$
-10% reflection of this frequency component

Impedance Profile – How do we use it?

-We can estimate the maximum data rate from the impedance profile

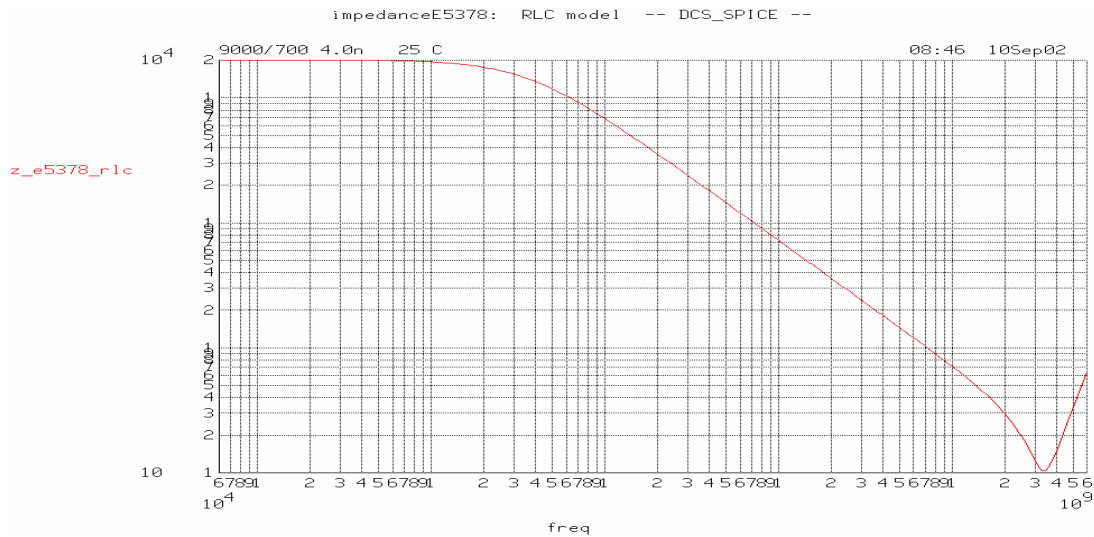

- Set the 3rd harmonic of the fundamental frequency at the resonant point
- multiply the fundamental by 1.5 to find the data rate (w/ some margin)

$$\text{ex) transfer rate} = \left(\frac{\text{probe resonant freq}}{3} \right) * 1.5$$

(b/s) (Hz)

$$\text{transfer rate} = \left(\frac{3\text{GHz}}{3} \right) * 1.5 = 1.5\text{Gb/s}$$

Probing Location

-The location of the probe affects

- the target signal integrity **AND**
- the probe signal integrity

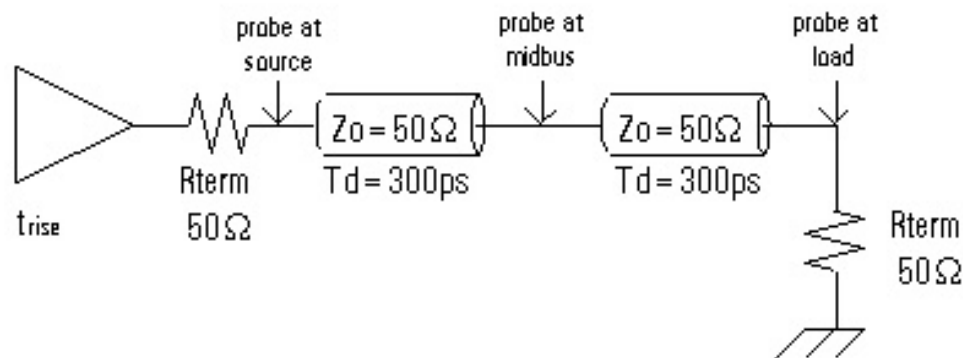

- The termination scheme and parasitics of the target affect the performance of the probe
- The location and loading of the probe affect the performance of the target

Probing Location Example #1

- Load Terminated System
- Probing at **Source**

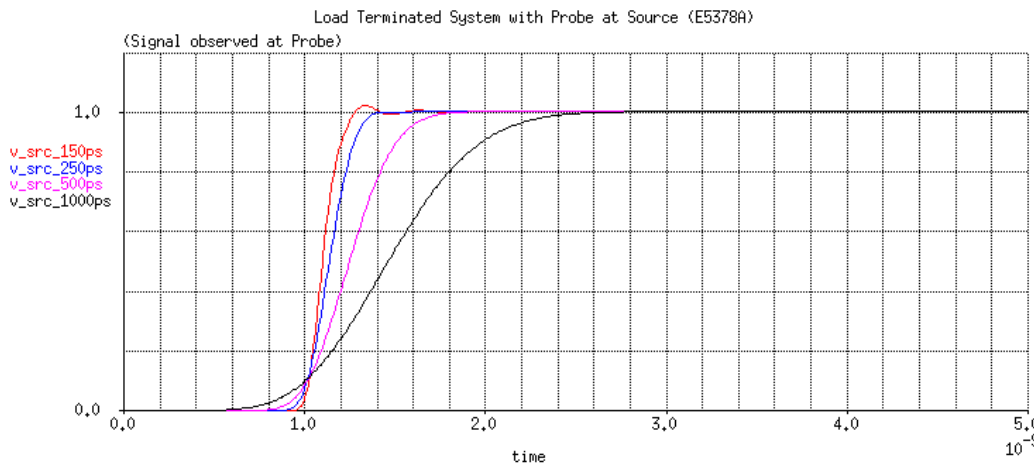
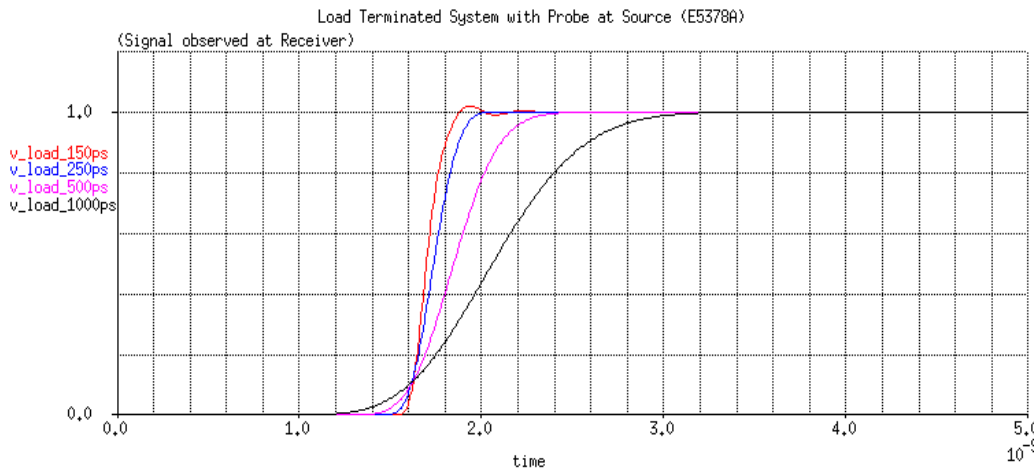

- **4 risetimes are shown**
- **150ps, 250ps, 500ps, and 1000ps**
- **Higher risetimes have higher frequency components which will see the “undesirable” regions of the probes response**
- **The response is good for both the target and the probe**

Probing Location Example #2

- Load Terminated System
- Probing at **Midbus**

- The positive reflection present is due to the reflection of the discontinuity and its re-reflection off of the source.

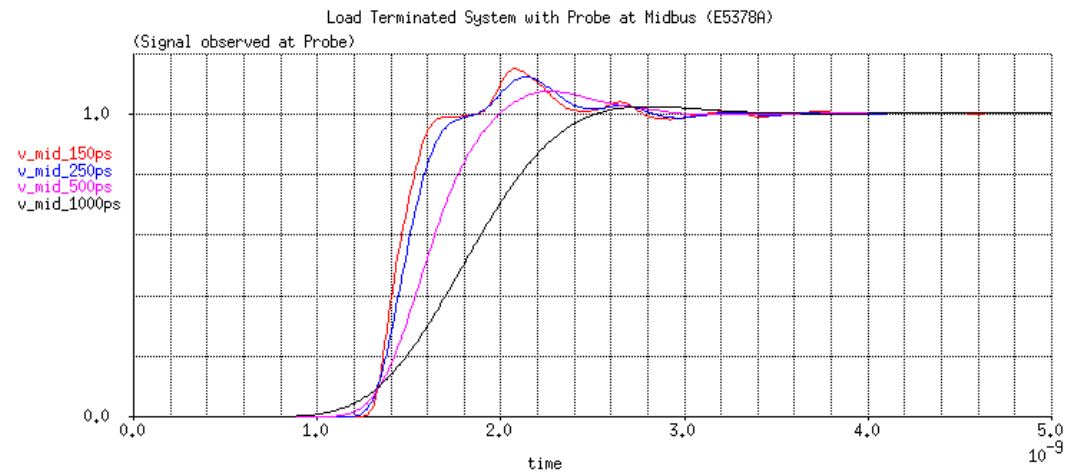
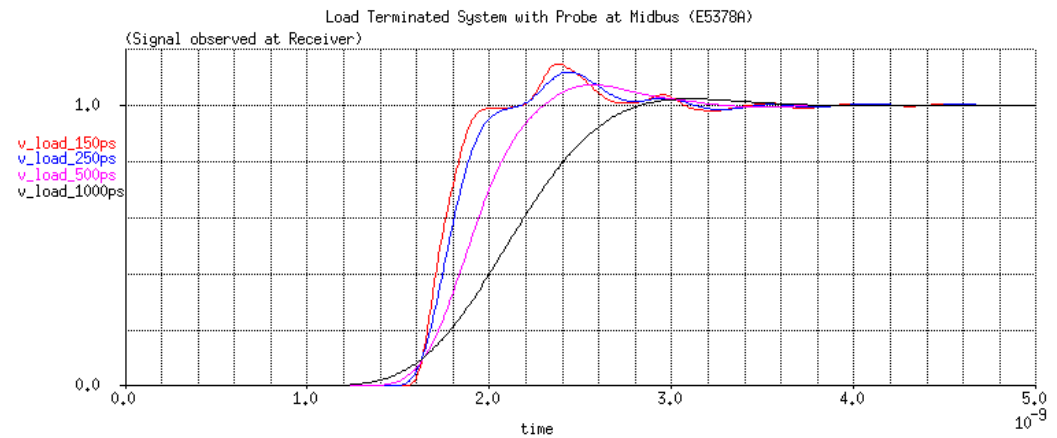

Probing Location Example #3

- Load Terminated System
- Probing at **Load**

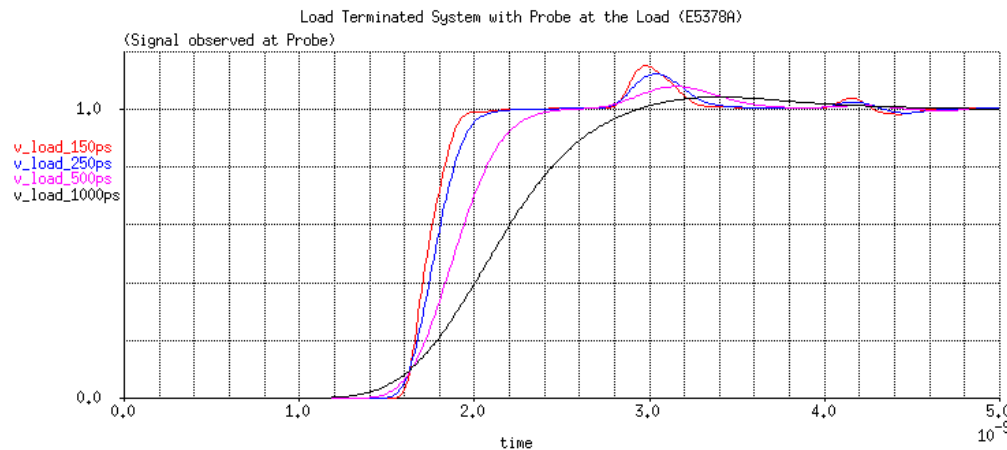
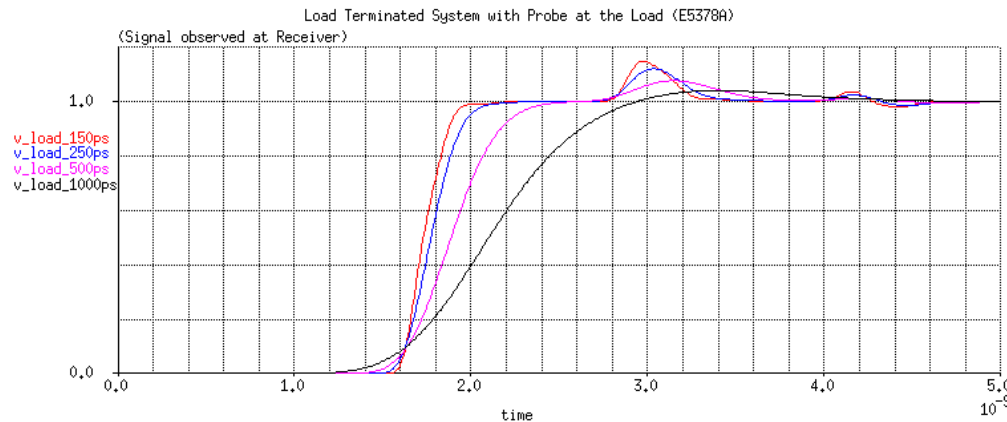

- Again, The positive reflection present is due to the reflection of the discontinuity and its re-reflection off of the source.
- Although in this case, it is further out in time.

Probing Location Example #4

- Source Terminated System
- Probing at **Source**

- The response at the receiver looks acceptable.
- However, the response at the probe tip is unacceptable.
- The flat region will be an “undetermined” logic level by the logic analyzer.

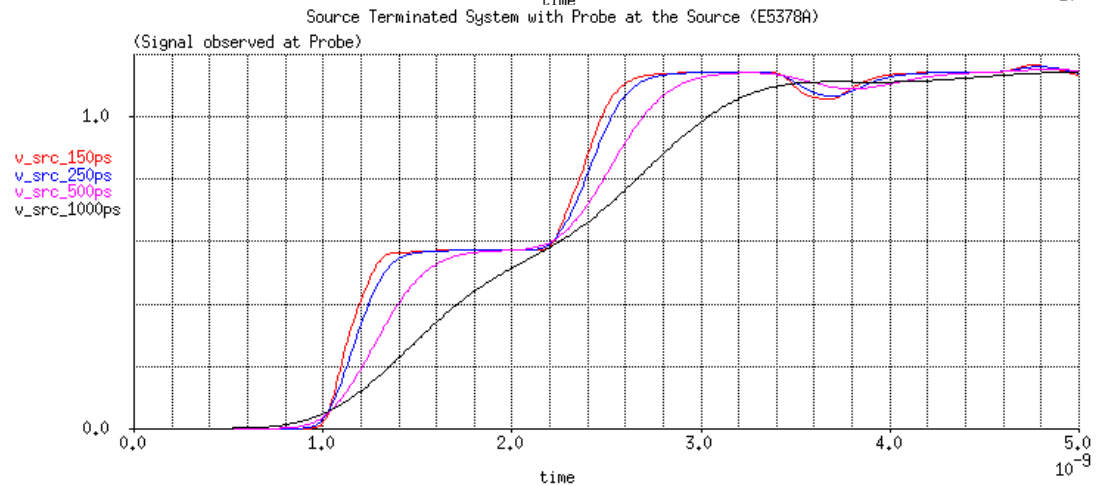
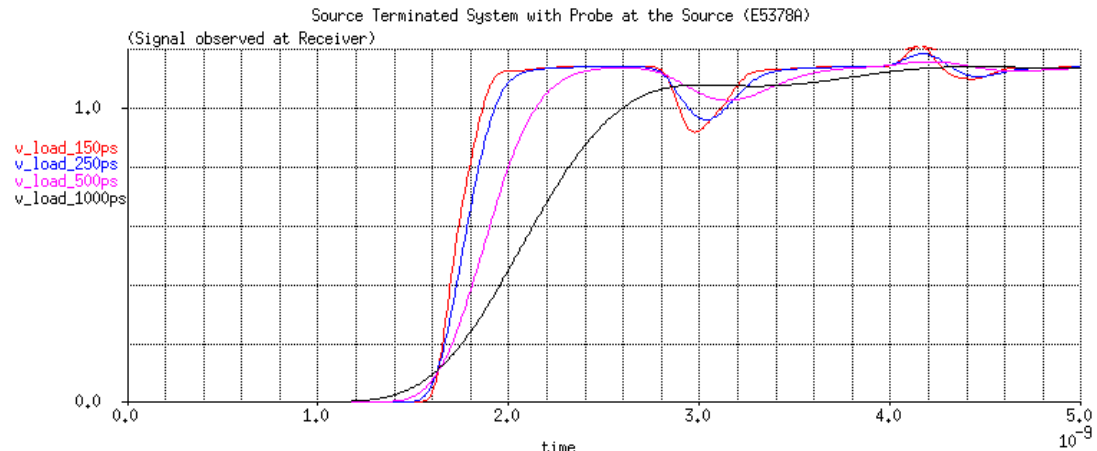

Probing Location Example #5

- Source Terminated System
- Probing at **Midbus**

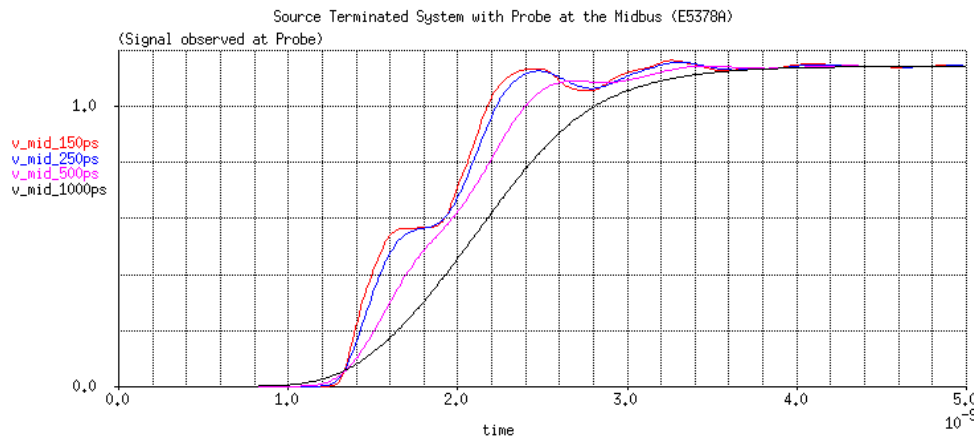
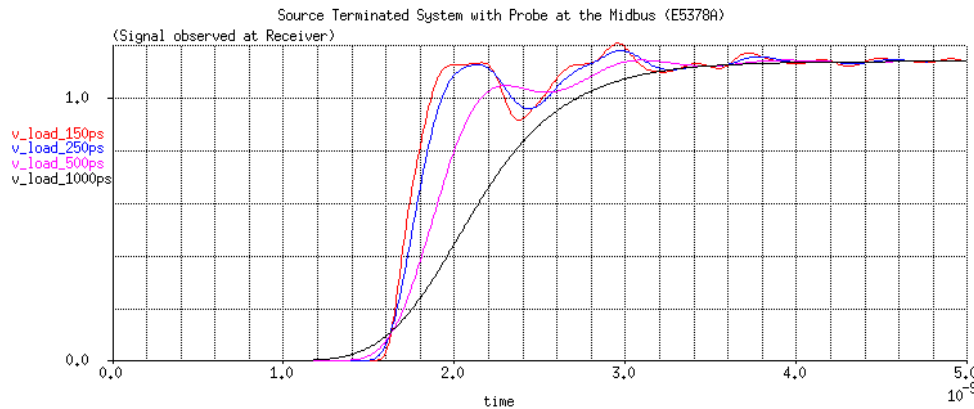

- Again, the flat region is present in the signal that the probe tip sees. This is unacceptable for the logic analyzer.

Probing Location Example #6

- Source Terminated System
- Probing at **Load**

- The response looks good at both the receiver and the probe tip.
- This is the optimal place to probe a source terminated system.

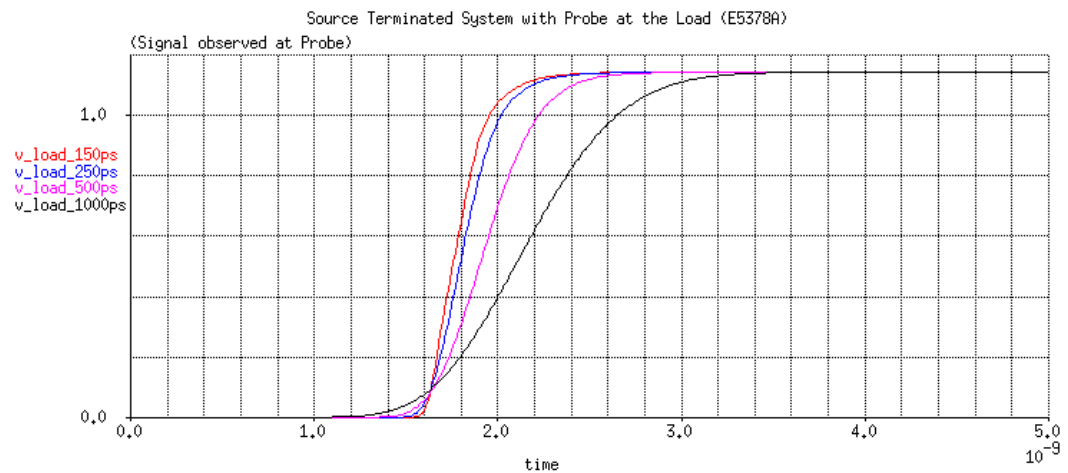
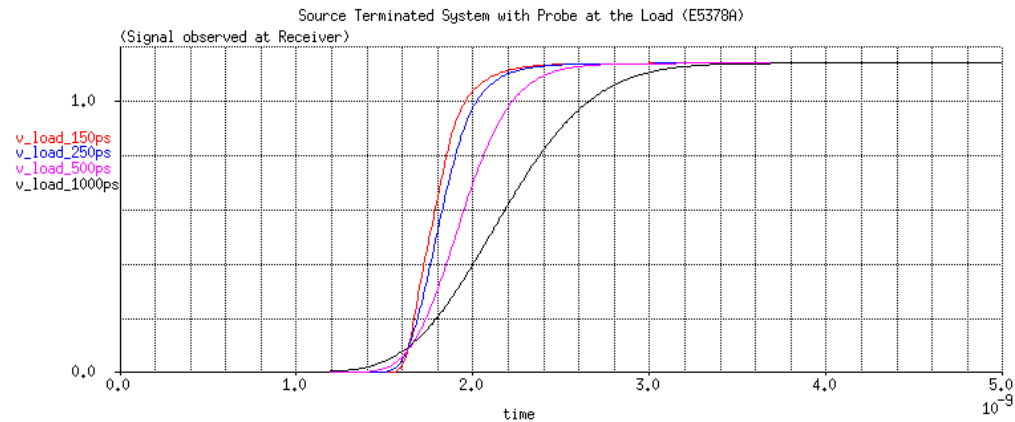

Probing Location Summary

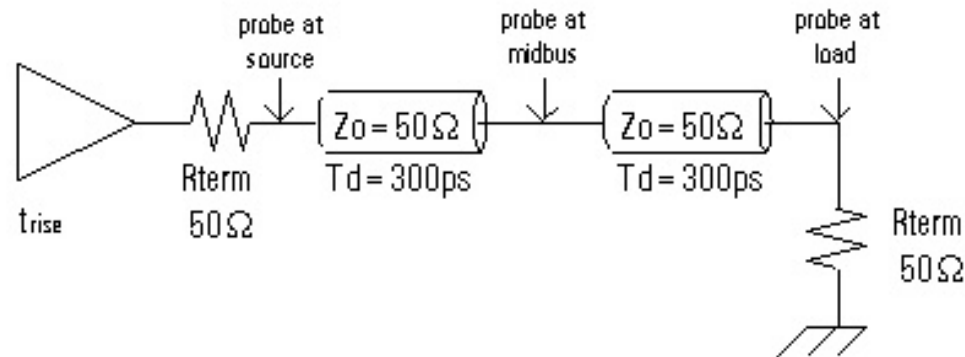

- 1) For a Load-Terminated System – place probe at the Source
- 2) For a Source-Terminated System – place probe at the Load
- 3) For a Double-Terminated System – place probe at Midbus

The reason for placing the probe at the midbus is to reduce its effective time constant. Placing the load in the middle of the transmission line will give an effective R of $Z_0 // Z_0$ (usually 25Ω 's)

Probing Comparison

- The evolution of Logic Analyzer Probes has given the user the following:

- 1) Lower Capacitive Loading
- 2) Higher Resonant Frequency of the Probe Load
- 3) Higher Bandwidth Probes
- 4) Denser Connections

Probing Comparison

- The following examples show a comparison between 4 popular logic analyzer probes:

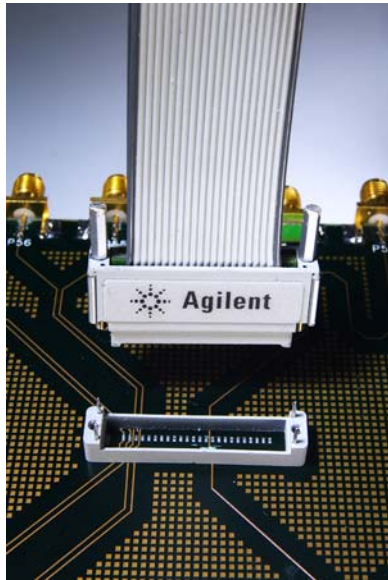

E5387A
Soft-Touch
(Clload = 0.7pF)



E5381A
Flying Lead
(Clload = 0.9pF)



E5378A
Samtec
(Clload = 1.5pF)



E5380A
Mictor
(Clload = 3.0pF)

Probing Comparison #1

- Load Terminated System
- Probing at **Midbus**

Load Terminated System with Probe at the Midbus (E5387A, E5381A, E5378A, E5380A)

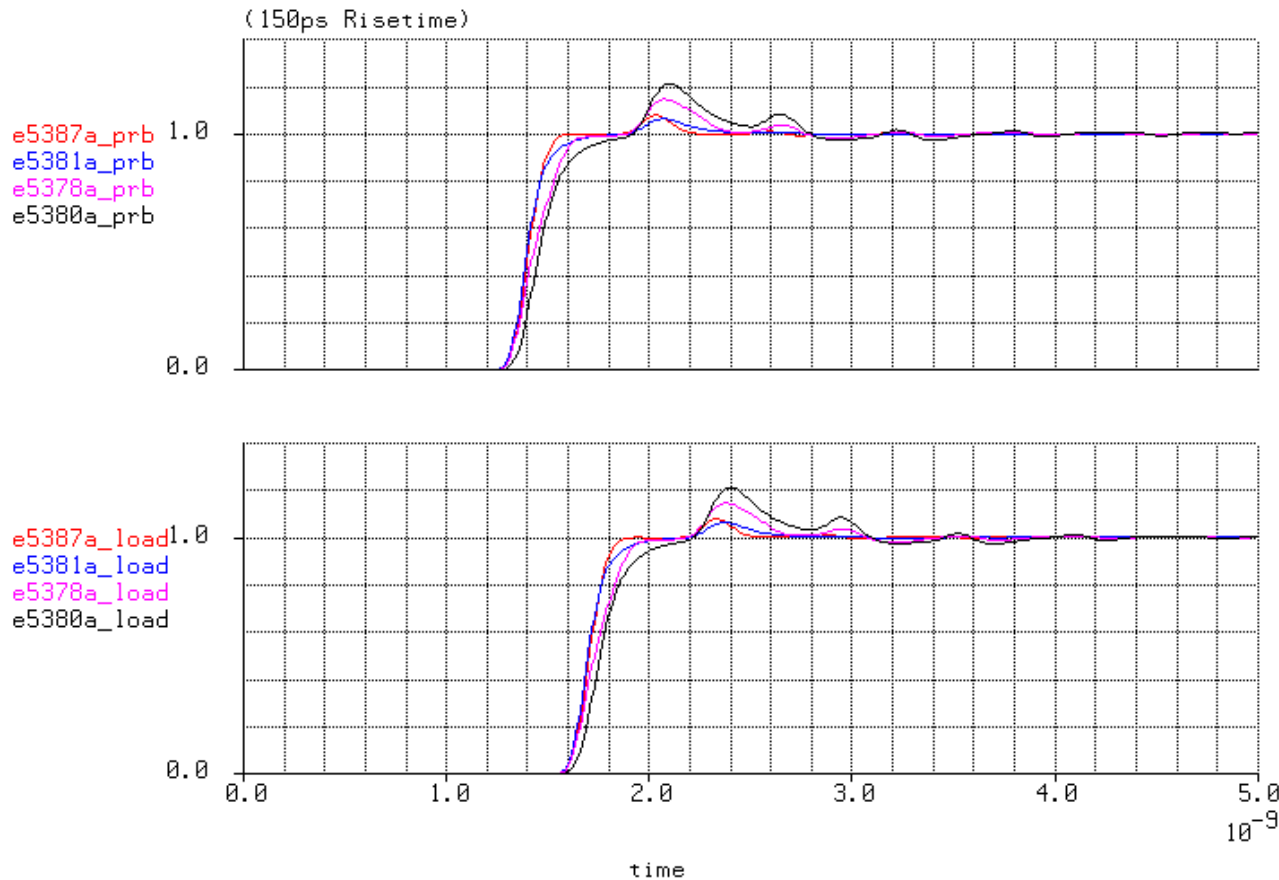

- A 150ps risetime is shown for each probe load.

- This shows that as the probes evolve, the affect on the target system is reduced.

Probing Comparison #2

- Source Terminated System
- Probing at **Midbus**

Source Terminated System with Probe at the Midbus (E5387A, E5381A, E5378A, E5380)

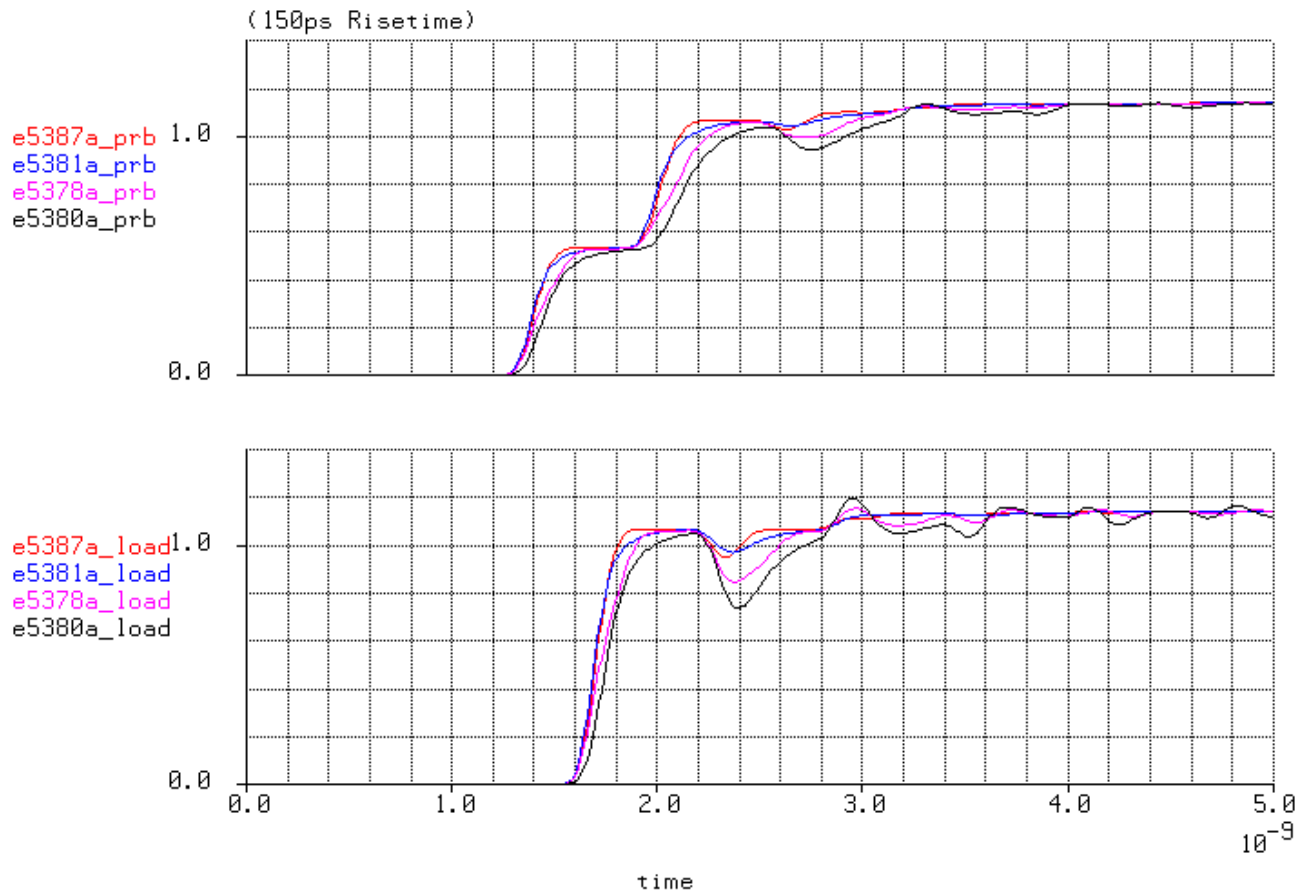

- Again, the affect of the new logic analyzer probe on the target system is significantly less that the older probes.

Specific Probing Techniques

- Until now, we have assumed that the probe tip is directly connected to the target system without any distance between the two.
- In reality, the probe tip will have a finite distance between the target transmission line and the probe.
- The question then becomes, "How far away from the target can the probe tip be?"

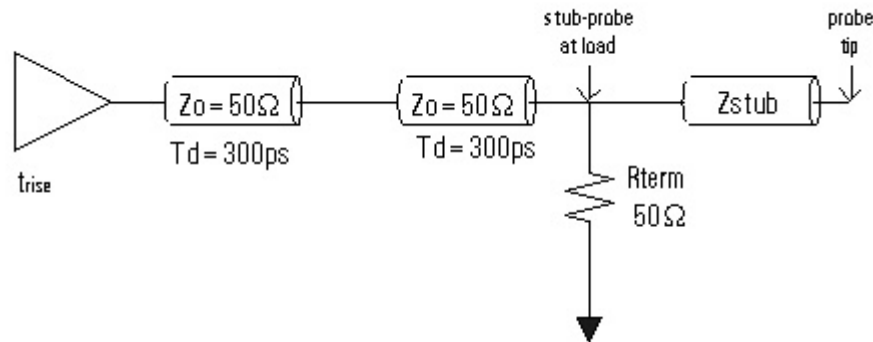

Specific Probing Techniques

(Stub-Probing)

- When there is a stub between the probe tip and the target, this is referred to as "Stub-Probing"
- The general rule is "No-Stubs"
- Any stub will add capacitive loading to the target and roll-off the signal that the analyzer sees.

Ex) The E5387A Probe ($C_{load}=0.7\text{pF}$) is located 1" away from the target connected through a 50 ohm microstrip line ($C=3\text{pF/in}$).

The total capacitive load of the probe is now 3.7pF.
The capacitance of the stub has dominated the loading of the probe.

Even 1" is a lot!



Specific Probing Techniques

(Stub-Probing)

- The rule of thumb is to keep the electrical length of the stub less than 20% of the target's risetime.
- This allows the stub to be treated as a lumped capacitance and its adverse affects on the system can be easily predicted.
- If the stub is longer than this, the stub becomes a transmission line and reflections must be considered. **This is BAD**

Specific Probing Techniques

(Stub-Probing Example)

- Given a system with:
- load terminated system
 - propagation delay = 150ps/in
 - trace capacitance = 3pF/in
 - 1" stub between probe and load

<u>Risetime</u>	<u>Max-Electrical-Length</u>	<u>Max-Physical-Length</u>	<u>Capacitance</u>
150ps	$150\text{ps} \cdot 0.2 = 30\text{ps}$	$(30\text{ps}) / (150\text{ps}/\text{in}) = 0.2''$	$(.2'') \cdot (3\text{pF}) = 0.6\text{pF}$
250ps	$250\text{ps} \cdot 0.2 = 50\text{ps}$	$(50\text{ps}) / (150\text{ps}/\text{in}) = 0.33''$	$(.33'') \cdot (3\text{pF}) = 1.0\text{pF}$
500ps	$500\text{ps} \cdot 0.2 = 100\text{ps}$	$(100\text{ps}) / (150\text{ps}/\text{in}) = 0.67''$	$(.37'') \cdot (3\text{pF}) = 2.0\text{pF}$
1000ps	$1000\text{ps} \cdot 0.2 = 200\text{ps}$	$(200\text{ps}) / (150\text{ps}/\text{in}) = 1.33''$	$(1.33'') \cdot (3\text{pF}) = 4.0\text{pF}$

- Only for the 1000ps risetime can we treat the 1" stub as a lumped capacitance.
- The 150ps, 250ps, and 500ps risetimes will see a distributed load and have reflections.

Specific Probing Techniques

(Stub-Probing Example)

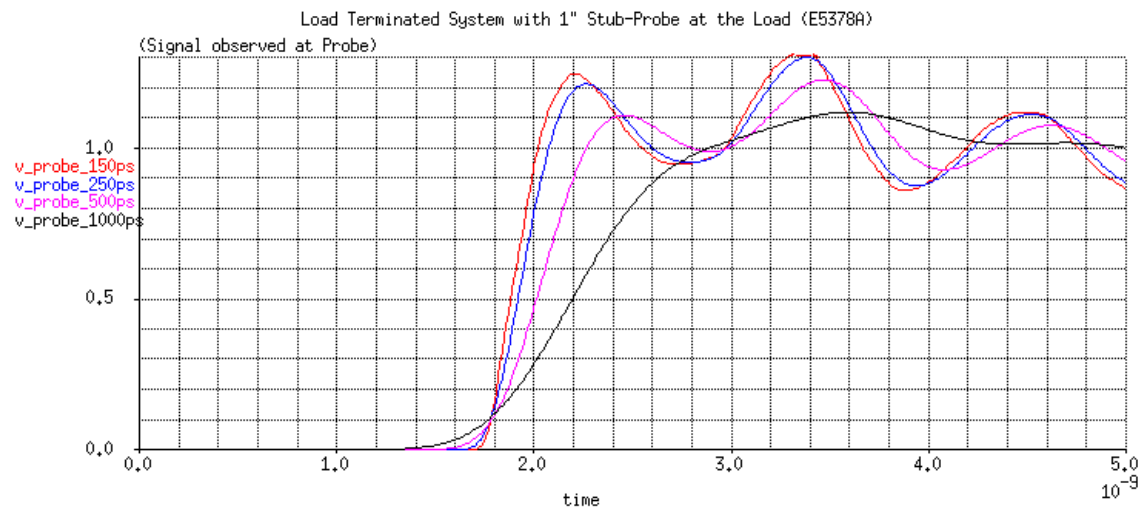
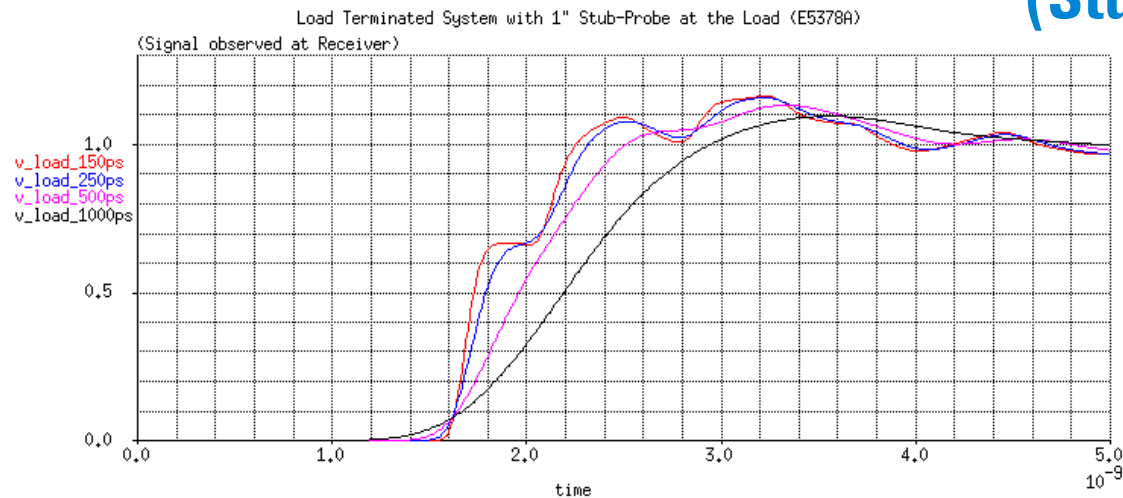

- The 1000ps risetime is rolled off but does not have reflections.

- The faster risetimes are seeing considerable ringing due to reflections off of the stub-probe.

- Summary: The faster the risetime, the shorter the stub that can be tolerated.

Specific Probing Techniques

(Damped Resistor Probing)

- If a stub cannot be avoided, a method called “Damped Resistor Probing” can be used.
- In this method, a resistor is placed at the target. This feeds a length of trace connecting to the probe tip.
- This allows a longer length of trace to be used to connect to the probe tip.

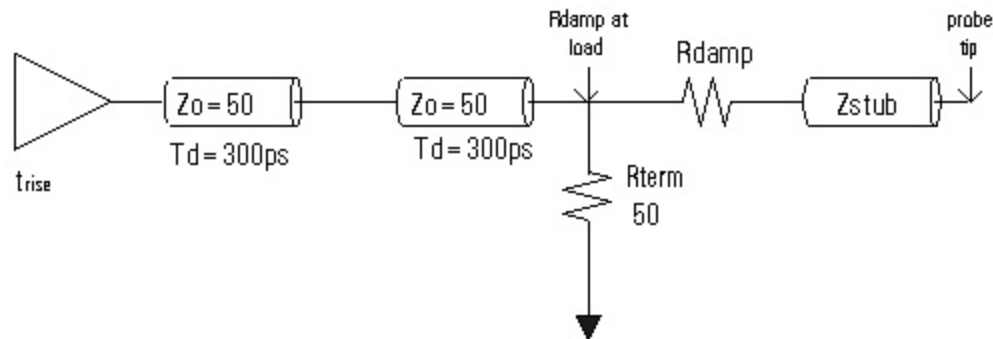

The Damping resistor does two things:

- 1) It isolates the target from the trace capacitance**
- 2) It dissipates the reflection energy contained on the stub**

Specific Probing Techniques

(Damped Resistor Probing)

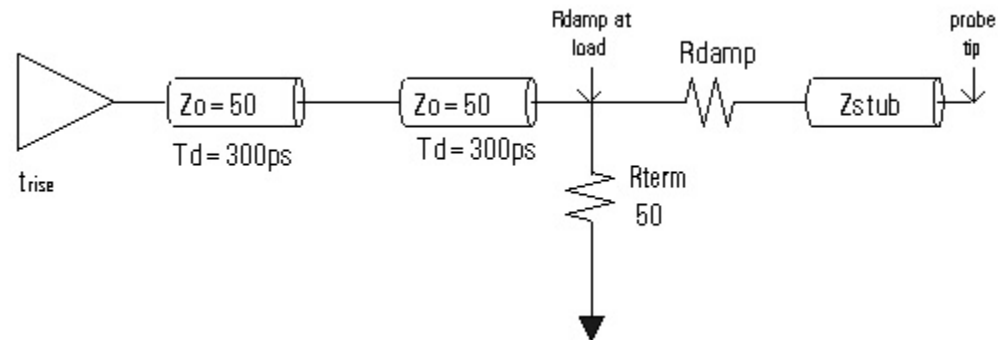

Damped Resistor Consideration:

- 1) The damping resistor and the trace capacitance will form an RC filter that will roll off the signal that the analyzer sees.
- 2) The maximum length of the trace will be dictated by the bandwidth needed at the probe tip.

Specific Probing Techniques

(Damped Resistor Probing)

Damped Resistor Design Rules:

- 1) Choose a damping resistor that is 2.5x the impedance of the target.
- 2) Keep the stub trace impedance as high as possible. This will reduce the capacitance per inch of the trace.

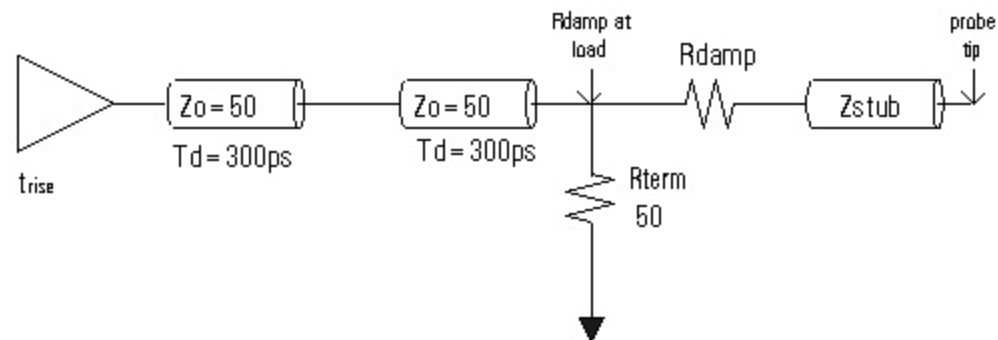

Specific Probing Techniques

(Resistive Divider Probing)

- If a longer stub is needed than the “Damped-Wire” can provide, then consider a method called “Resistive-Divider-Probing”

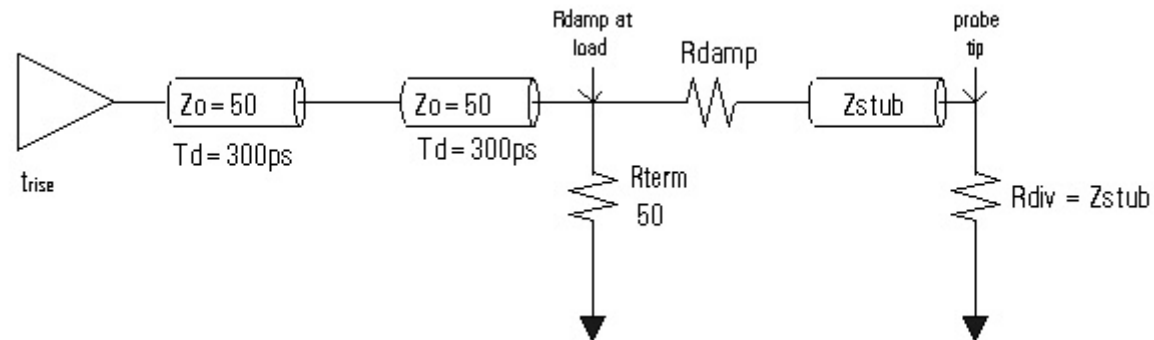

- In this method, a damping resistor is again used.
- However, at the end of the stub where the probe tip is, a termination resistor is placed.

Specific Probing Techniques

(Resistive Divider Probing)

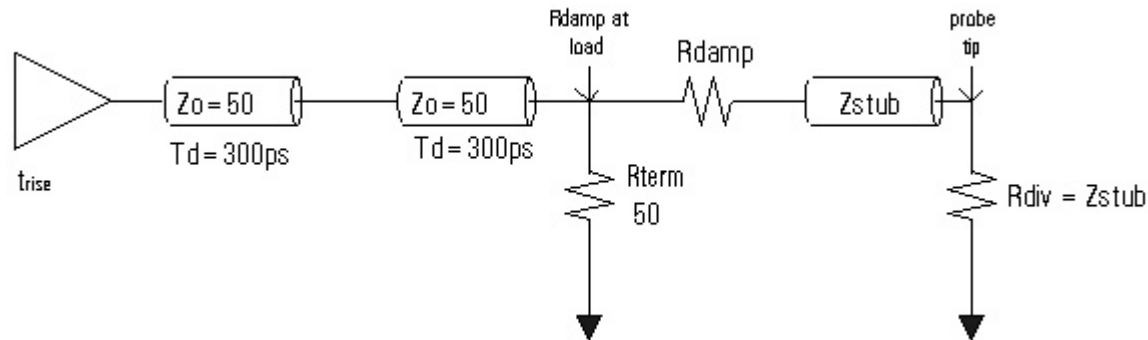

- The termination resistor turns the stub into a controlled impedance transmission line which can have a very long length without reflections.

Resistive Divider Probing Considerations

- 1) The R_{damp} and R_{div} will form a voltage divider. This reduces the signal amplitude that the probe tip sees.
- 2) The amplitude must not be divided down past the "minimum allowable voltage level" dictated by the logic analyzer.

Specific Probing Techniques

(Resistive Divider Probing)

Resistive Divider Design Rules

- 1) Choose a damping resistor that is 2.5x the impedance of the target.
- 2) Keep the stub trace impedance as high as possible.
- 3) Choose Rdiv to match the impedance of the trace connecting to the probe tip.
- 4) By keeping the trace impedance high, it will reduce the divider ratio that is formed by this technique.

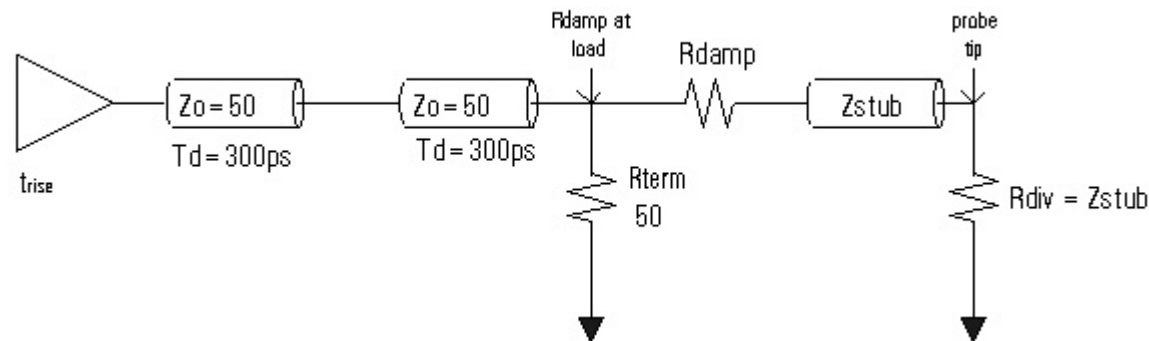

Electrical Performance Summary

1) Methods for predicting the affect of the probe on the target:

- lumped capacitance hand-calculations
- impedance profile extraction
- simulation of equivalent load model **(BEST)**

2) Variables that affect the performance of the system and probe:

- probe load
- probe location
- target topology and margins

3) Specific probing Techniques:

- place probe tip directly on the target **(BEST)**
- stub-probing
- damped-wire probing
- resistive divider probing

Modern Probing Solutions

Modern Logic Analyzer Probes fall into one of the four categories:

- 1) Connector-Based**
- 2) Connector-Less**
- 3) Flying Lead**
- 4) Custom**

Modern Probing Solutions

“Connector-Based”

- The user puts down a pre-defined connected on the target system.
- Signals are routed to the connector
- A logic analyzer probe with the opposite sex connector is plugged in



Advantages:

- 1) Easy to connect to target
- 2) Robust Connection

Modern Probing Solutions

“Connector-Less”



- The user puts down a ‘landing pattern’ on the target system.
- The connector-less probe is then attached to the system with a ‘retention module’

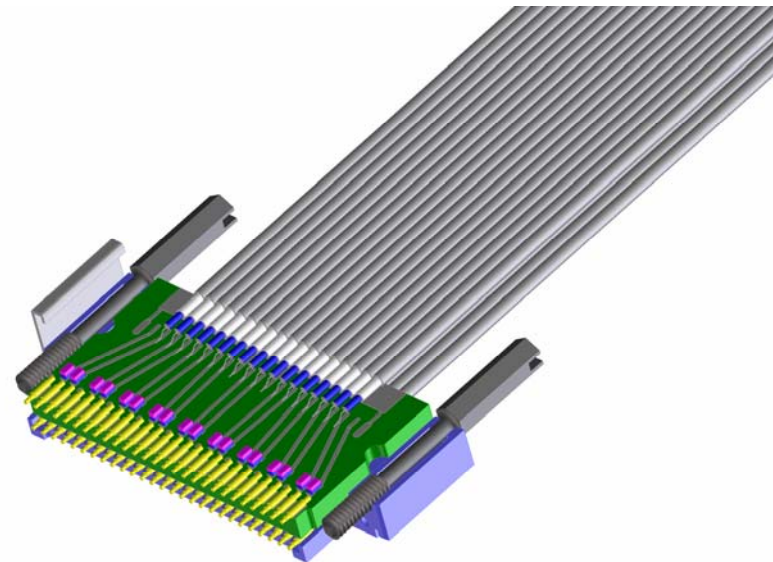
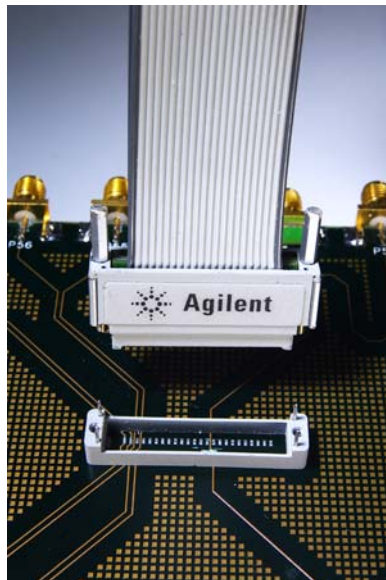

Modern Probing Solutions

“Connector-Less”

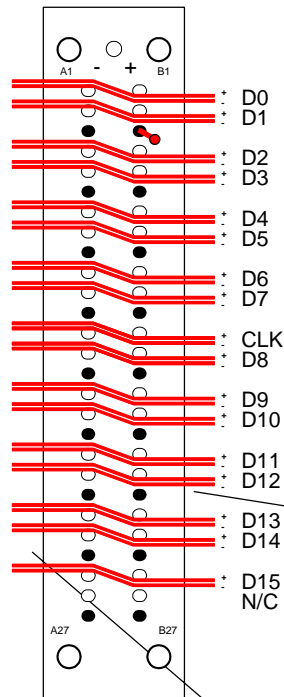

Advantages:

- 1) No connector is needed so cost is reduced on the target.
- 2) Since the signal doesn't go through a connector, loading is reduced. ($\sim 0.7\text{pF}$)
- 3) Signal routing is improved.
- 4) Signal Density is increased

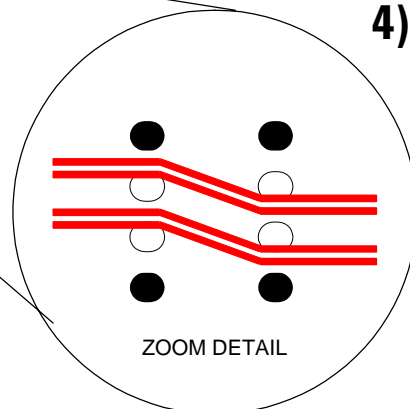

Modern Probing Solutions

“Flying Lead”

- General Purpose



Advantages:

- 1) Signals that are not routed to a connector can be probed.
- 2) Accessories make most connections possible.
- 3) Full Bandwidth

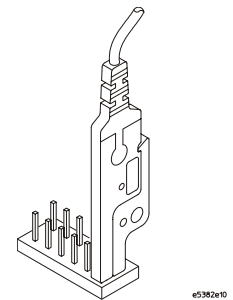
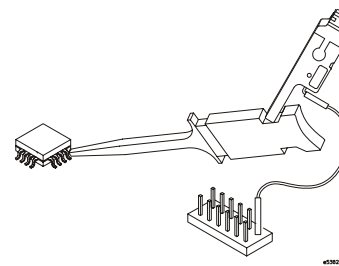
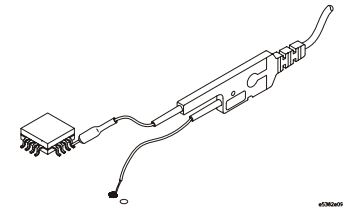
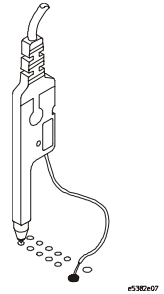

Modern Probing Solutions

“Custom”

- Designed specifically for an application or form factor

Ex) processors, microcontroller, memories, etc...

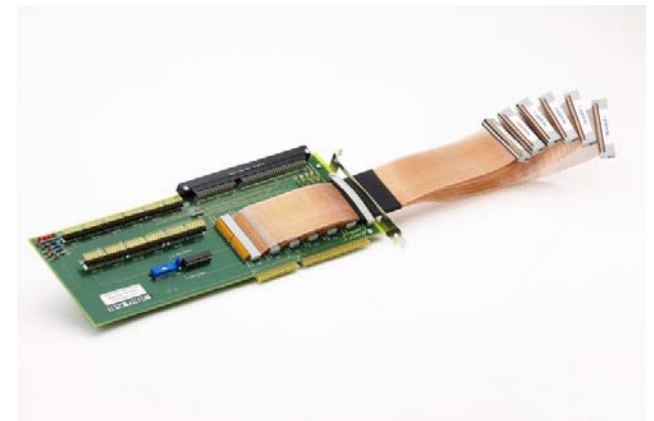
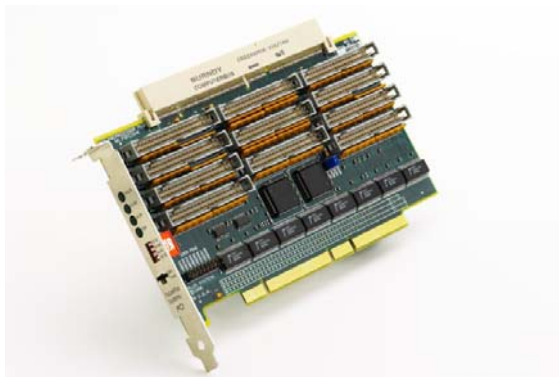

Summary

- 1) Electrical Affects of the target and the probe must be considered.**
- 2) Mechanical Constraints of the probe must be considered.**
- 3) Both electrical and mechanical affects contribute to the probes usefulness.**
- 4) Many probing techniques are available to ensure successful probing of a high-speed digital system.**
- 5) A variety of probe form-factors are available to best meet the need of industry.**

Questions?

